

## Creating the Arc Elements

**Step 1**  
Begin by creating Circle 1 the exact width of the application.

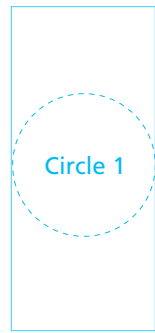

**Step 2**  
Scale Circle 1 up 300% of the width of the application.

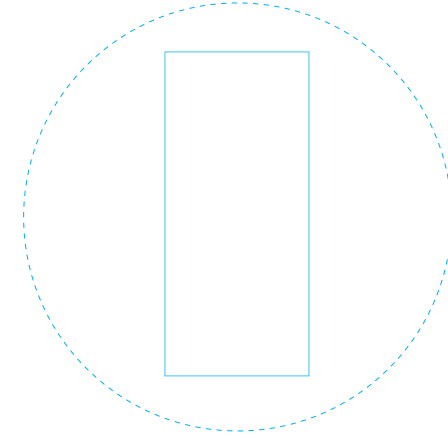

**Step 3**  
Using the X axis of Circle 1, place the top of Circle 1 two inches down from the top of the application. Circle one can only be positioned on the left or right side of the application. The result is the top staging area of the application.

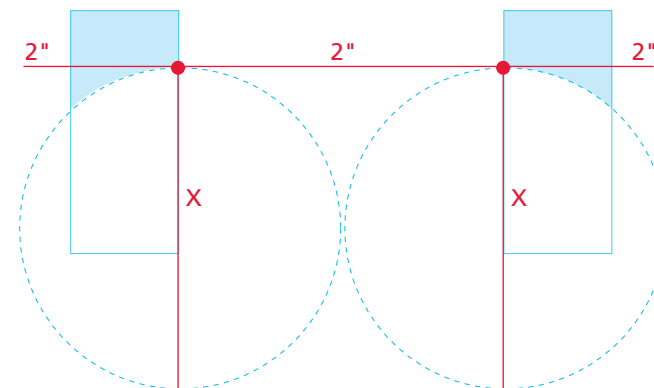

Circle 1  
Preferred  
Right Placement

Circle 1  
Optional  
Left Placement

**Step 4**  
Circle 2 is created in the same manner as Circle 1. However, Circle 2 is used to create the bottom staging area of the application. Using the X axis, place Circle 2 two inches up from the bottom of the application from left, to center, to right.

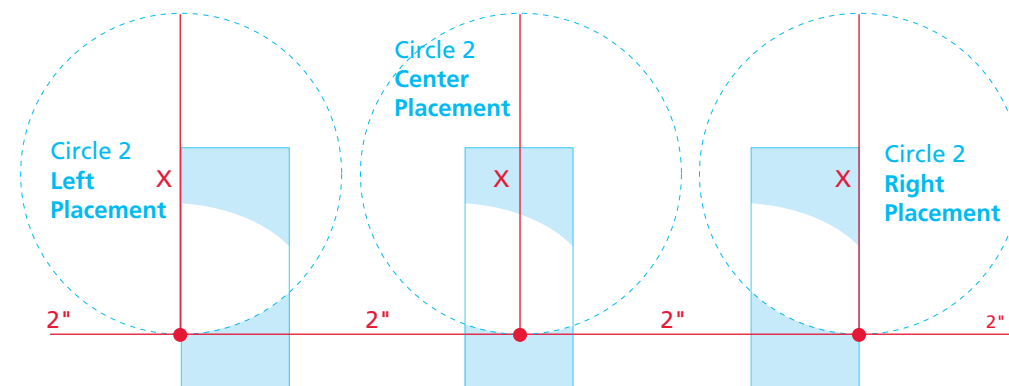

Circle 2  
Left  
Placement

Circle 2  
Center  
Placement

Circle 2  
Right  
Placement

**Step 5**  
Circle 3 is considered the accent circle and is the most flexible of all the three circles. The accent circle may interact and accent the top and bottom staging areas in a variety of ways. However, the accent circle may never exceed the two inch margin in either the top or bottom staging areas and can only interact with one at a time.

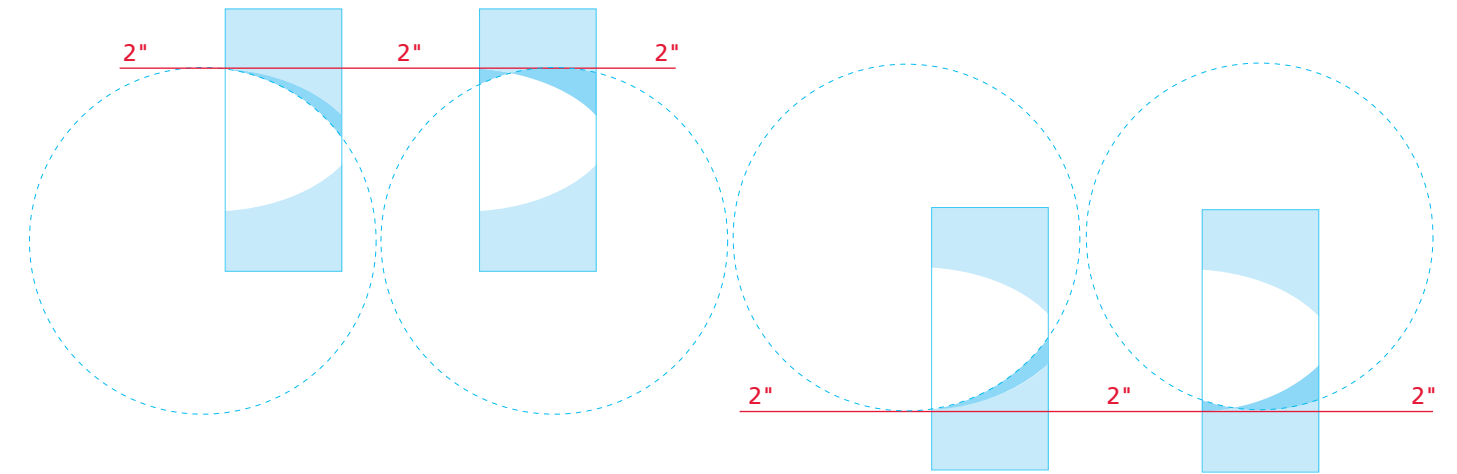

### Special Circumstances

In some cases the 2" standard may be adjusted. However, the minimum distance is 1/2". When adjusting this standard always use increments of 1/2". When using less than two 2", be sure to leave enough of a staging area for the logo.

It is always recommended that the 2" standard be used whenever possible.

