



Setting the Standard for Automation™

ISA100.11a, Release 1

An Update on the First Wireless
Standard Emerging from the
Industry for the Industry

Standards
Certification
Education & Training
Publishing
Conferences & Exhibits

ISA100.11a Working Group Scope

This project will define all specifications including security and management; for wireless devices serving application classes 1 through 5 for fixed, portable and moving devices.

The project's application focus will address performance needs for periodic monitoring and process control where latencies on the order of 100 ms can be tolerated with optional behavior for shorter latency.

ISA100 Usage Classes

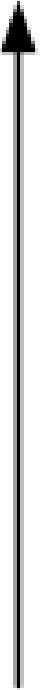
<i>Category</i>	<i>Class</i>	<i>Application</i>	<i>Description</i>	Importance of message timeliness increases 
<i>Safety</i>	0	Emergency action	(always critical)	
<i>Control</i>	1	Closed loop regulatory control	(often critical)	
	2	Closed loop supervisory control	(usually non-critical)	
	3	Open loop control	(human in the loop)	
<i>Monitoring</i>	4	Alerting	Short-term operational consequence (e.g., event-based maintenance)	
	5	Logging and downloading/uploading	No immediate operational consequence (e.g., history collection, sequence-of-events, preventive maintenance)	

ISA100.11a Working Group Charter

This project will address:

- **low energy consumption devices, with the ability to scale to address large installations**
- **wireless infrastructure, interfaces to legacy infrastructure and applications, security, and network management requirements in a functionally scalable manner**
- **robustness in the presence of interference found in harsh industrial environments and with legacy systems**
- **coexistence with other wireless devices anticipated in the industrial work space**
- **interoperability of ISA100 devices**

ISA100.11a WG Organization

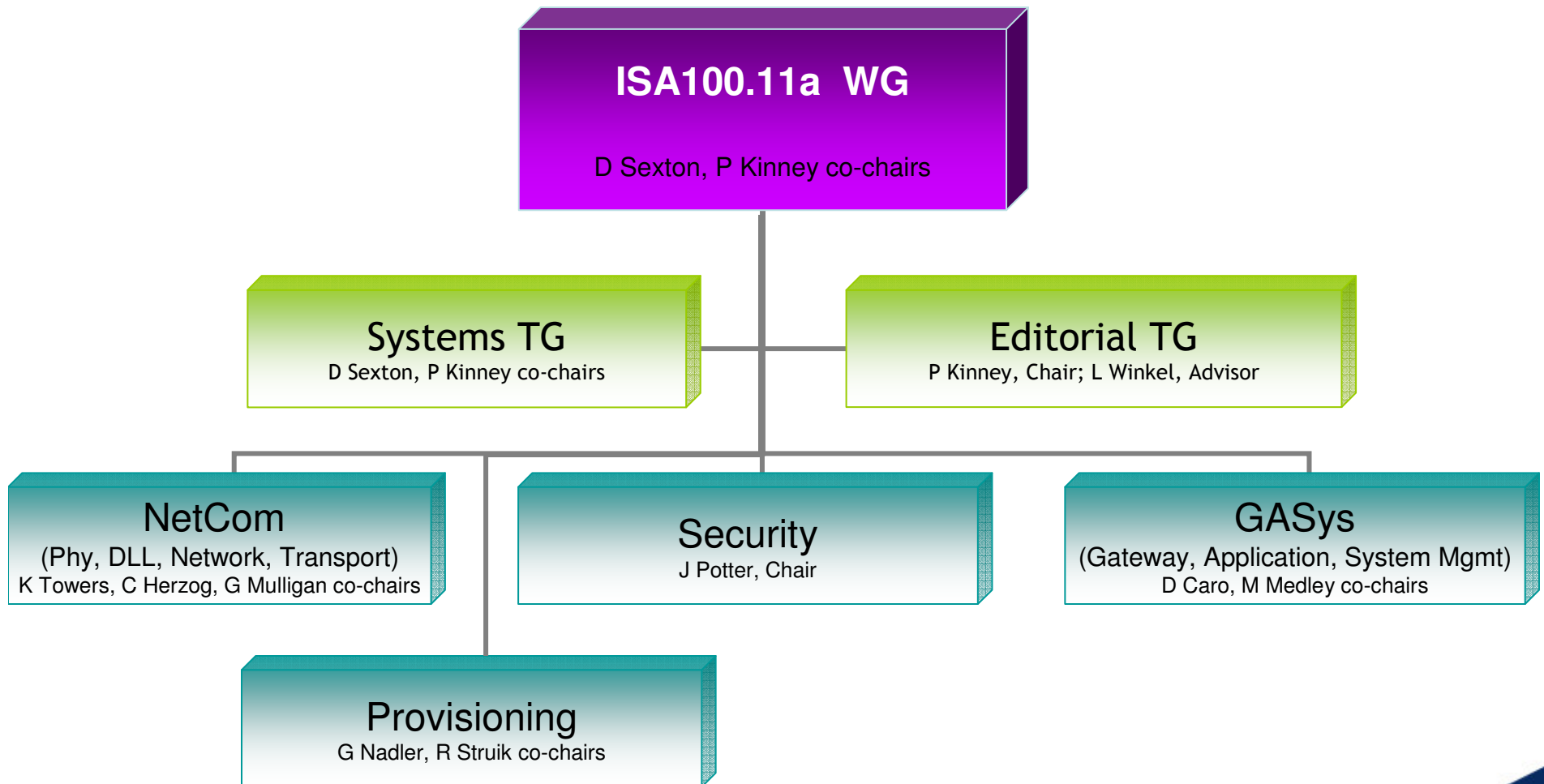

ISA100.11a Scope for Release 1

Be an open standard for anyone to implement and deploy

- No need to join any group
- Easily available via the internet
- No restrictions on downloads (other than copyrights)

Be simple to use and deploy for end users

- Written in a clear and concise manner
- Easy to navigate through the standard
- Address needs of users ranging from unsophisticated to networking experts

Assure multi-vendor device interoperability

- Standardize the necessary interfaces while leaving other aspects for vendor customization

ISA100.11a Scope for Release 1

Be focused on:

- **serving process industry applications without excluding factory automation**
 - Focus for release 1 is on process industrial applications
 - Architecture of ISA100.11a will support factory automation
- **in-plant/near-plant**
 - Focus on Local Area Networks (LANs) rather than Metropolitan Area Networks (MANs) or Wide Area Networks (WANs)
- **global deployment**
 - Choose radio bands and security techniques that are deployable throughout the world

Provide technology to address Class 1 (non-critical) to Class 5 applications such as monitoring

- Critical and extremely time sensitive applications will be served in later releases

ISA100.11a Scope for Release 1

Adhere to a comprehensive coexistence strategy

- Coexistence is the ability of wireless networks to perform their tasks in an environment where there are other wireless networks that may or may not be based on the same standard
 - Examples of other wireless networks not based upon the ISA100.11a standard are WiFi/IEEE 802.11, Bluetooth, WirelessHART, etc.
- Coexistence strategy includes:
 - Listen before talk
 - Short messages
 - Low duty cycle
 - Adaptive frequency hopping by channel blacklisting
 - Low power operation

ISA100.11a Scope for Release 1

Include only 2.4 GHz 802.15.4-2006 radios

- Single Physical layer to:
 - facilitate vendor interoperability
 - provide a simpler standard
 - expedite release of standard

Use channel hopping to support co-existence and increase reliability

- Channel hopping is where the channel is constantly changed by all nodes
- Hopping is a proven technique to minimize the impact of interference in a congested band
 - Bluetooth and military backpack radios use hopping

Offer field device meshing and star capability

- Star configurations can provide very quick response times that are necessary for some types of critical applications
- Mesh networks can offer increased robustness, enhanced reliability, greater tolerance to interference, etc

ISA100.11a Scope for Release 1

Use a single application layer providing both native and tunneling protocol capability for broad usability

- Native protocols allow efficient use of the bandwidth and provide for longer battery life of nodes
- Tunneling protocol allows the ISA100.11a network to carry existing protocols such as Fieldbus Foundation, HART, Profibus, Modbus, and others.
 - Allows existing installations to be easily converted to wireless

ISA100.11a Scope for Release 1

Provide simple, flexible, and scalable security addressing major industrial threats leveraging 802.15.4-2006 security

- **Security is a major design facet of ISA100.11a**
 - Includes total life cycle such as configuration, operation, maintenance, etc
- **Security is considered throughout the whole system not just at the Phy layer or MAC sub-layer**
 - Leveraging security aspects of the IEEE 802.15.4-2006 standard allows for reduced costs, quicker implementations, and a broad consensus of security experts

ISA100.11a Release 2 commitments

ISA100.11a Work Group agreed that release 2 will include:

- **Critical class 1 to 5 applications in addition to monitoring**
 - To address critical and/or time sensitive applications
- **Additional gateway functionality as needed**
 - Release 1 will standardize only basic functionality
- **Additional network manager functionality as needed**
 - Release 1 will standardize only basic functionality
- **Dual/alternate Phys such as narrow band frequency hopping, sub-GHz, licensed bands, high speed, 5 GHz, etc.; driven by user requirements**
 - Release 1 focused on only one radio that may not be appropriate for some applications and/or user needs

ISA100.11a Release 2 Proposed Roadmap

At an ISA100 meeting last year, the Marketing Working Group unanimously approved a motion to recommend development of the following standards for the ISA100 roadmap:

- Factory Automation (Discrete Focus)
- Building Automation (Industrial Facility Focus)
- Transmission & Distribution (Long Distance Focus)
- RFID (.21 - Tagging Focus)
- In collaboration with ISA99, Universal Wireless Security (Standard Security Focus for the ISA100 family of standards, Building on .11a)

Device Profiles

Device Profiles are defined with the ISA100.11a standard to prescribe the operation and features of specific devices required to assemble a network or system.

- Device Profiles are required to assure interoperability between products from different suppliers.
- Device profile examples: Field Device, Field router, Gateway, System manager, Time source, etc.

Application Profiles

Application profiles allow for tailoring of configuration options in a uniform manner to support various application needs

- Examples of various applications include: Equipment Monitoring and Supervisory control
- Application profiles can define a super set of requirements that allow users to more easily understand a devices capability and how to best apply it
- For example, an ISA100 application profile will enable support of an independent Wireless HART Network in an ISA100 dual-mode gateway
- Application profiles are not within the scope of the ISA100.11a standard but could be controlled via the Wireless Compliance Institute
- Application profiles allow for additional branding by ISA100.11a equipment suppliers.

ISA100.11a Document Deliverables

Principles of Operation (“internal” document for WG use)

Overview of how the system works along with explanations of what each ISO layer provides.

Descriptions of configuration and provisioning

Illustrates the architecture of the standard

Purpose is to validate the technical direction of editor team

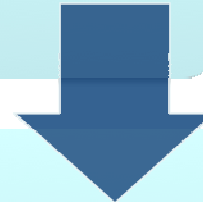

Preliminary Draft (“internal” document for WG use)

Preview of draft standard but with some omissions and TBDs

Purpose is to validate appropriate details of upcoming draft

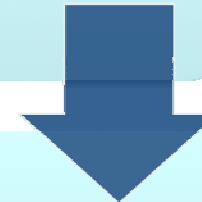

Release 1 Draft Standard

Includes short descriptions of general operation

States all of the requirements for compliance to the standard

Schedule

- Principles of Operation 15 August 2007
- Preliminary Draft 21 December 2007
- Draft Standard 27 March 2008
- WG letter ballot start 2 April 2008
- Comment Resolution period
- Committee Letter Ballot Start 5 September 2008
- Comment Resolution period
- ISA100 Approves ISA100.11a Standard 15 October 2008

Technical Overview

1. Background
2. Objectives
3. System
4. System Management
5. Physical layer
6. Data Link Layer
7. Network Layer
8. Transport Layer
9. Application sub-Layer
10. Gateway
11. Security

Technical Overview: Background Information

THE 7 LAYERS OF OSI

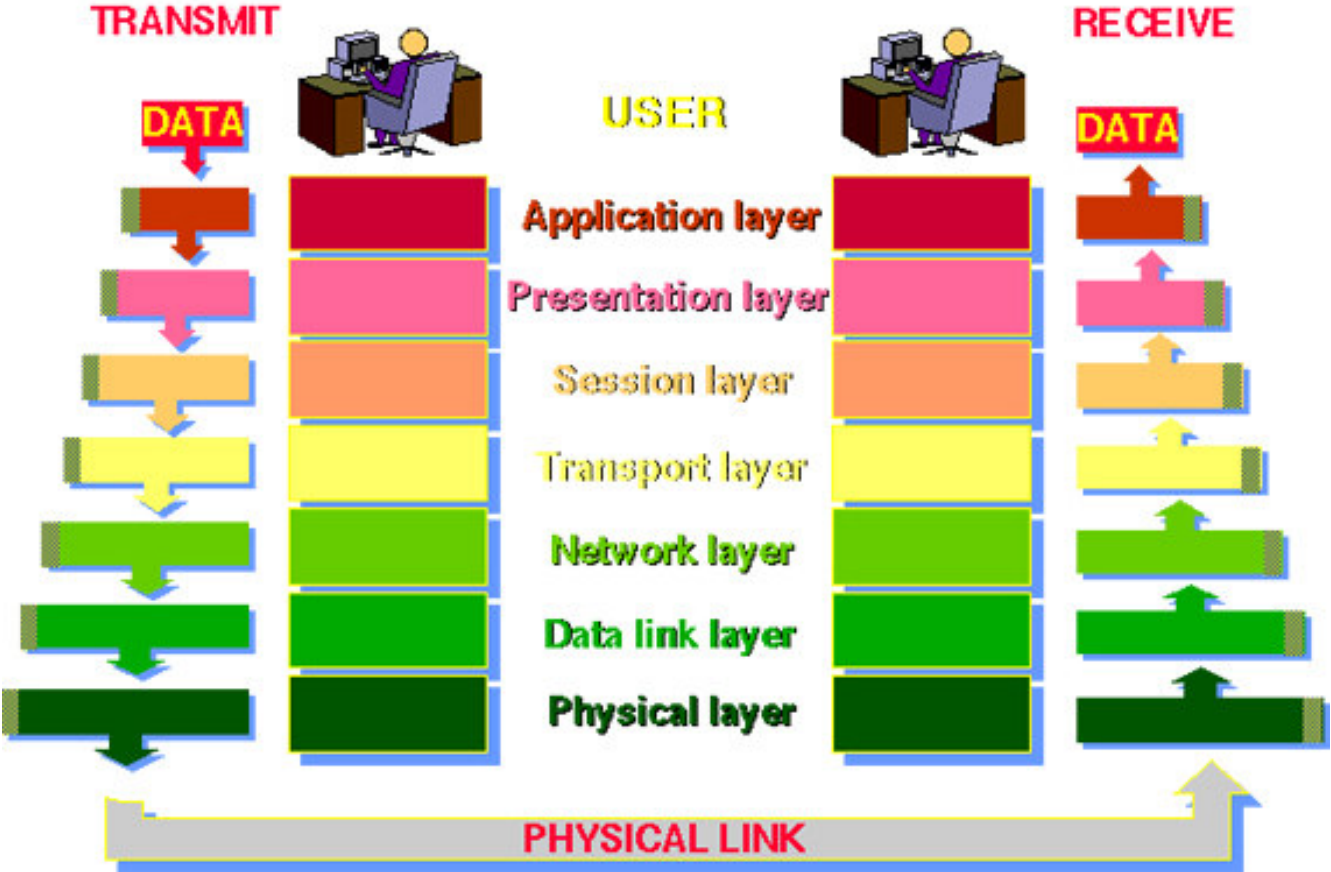

The Abdus Salam International Centre for Theoretical Physics
http://users.ictp.it/~radionet/1998_school/networking_presentation/index.html

Technical Overview: Objectives

- Release 1 provides reliable and secure operation for non-critical monitoring, alerting, supervisory control, open loop control, and closed loop control applications.
 - defines the specifications for low data rate wireless connectivity with fixed, portable, and moving devices supporting very limited power consumption requirements
- Application focused on needs for monitoring and process control
 - where latencies on the order of 100 ms can be tolerated
 - with optional behavior for shorter latency
- Provides robustness in the presence of interference found in harsh industrial environments and with legacy systems.
- Coexists with other wireless devices anticipated in the industrial work space as well as providing interoperability of ISA100 devices.
- Open standard that is intended to be of low complexity for end users to use and deploy

Technical Overview: System

How each ISO layer works together to accomplish system functionality

- ISA100.11a covers networks of wireless devices connected to an application.
- To accomplish this, a full specification from the physical layer to the application layer is required.
- ISA100.11a will define suitable interfaces to allow for those components typically used in a complete system but are not within the scope of ISA100.11a
- The network configuration has a series of wireless field devices, some of which can and will route messages, and some of which may not have routing capabilities or may not be configured to use routing capabilities.
- The network is attached to a user application at a gateway.
 - The gateway provides the transition from ISA100.11a into the users' application.

Technical Overview: System

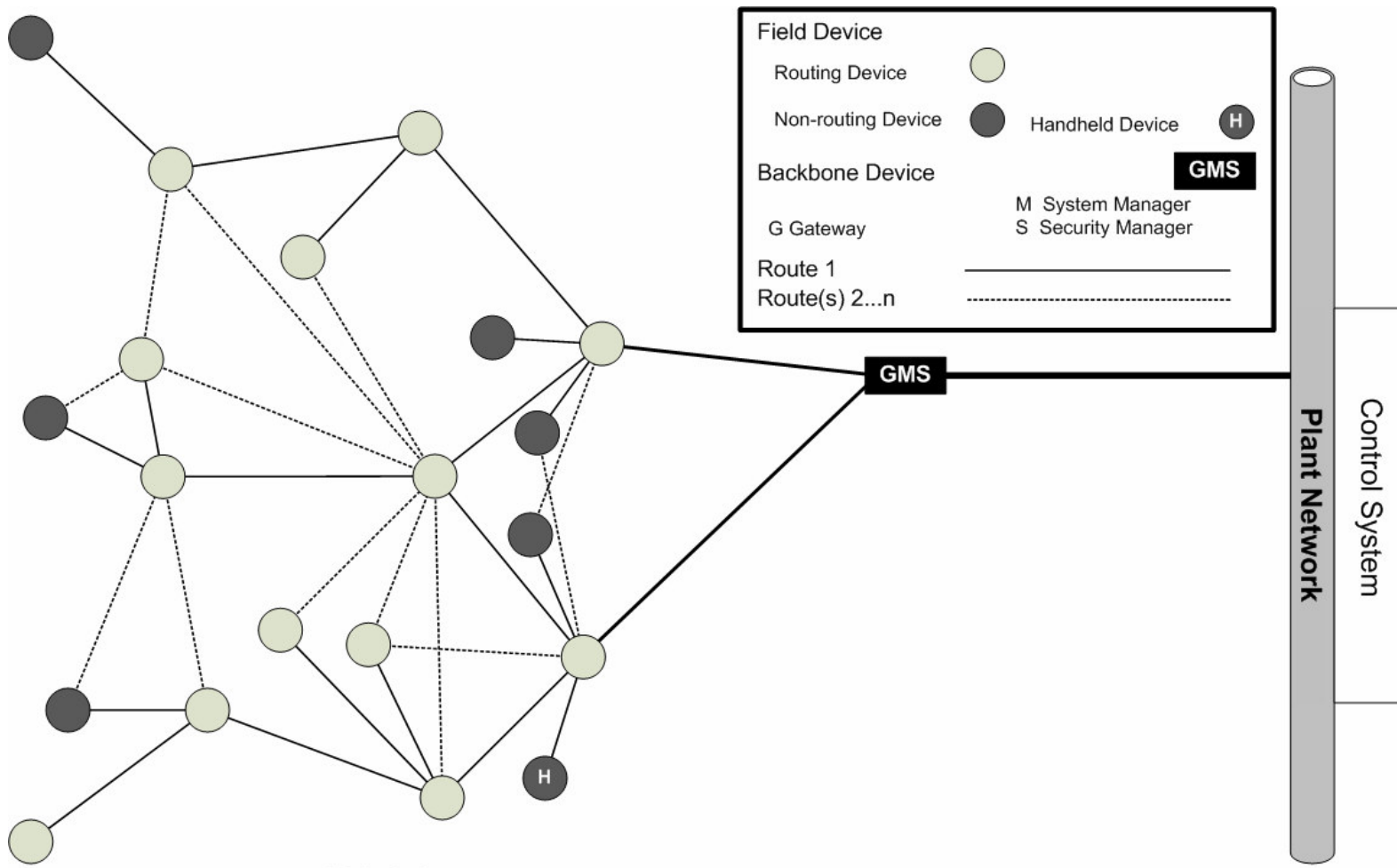

Technical Overview: System

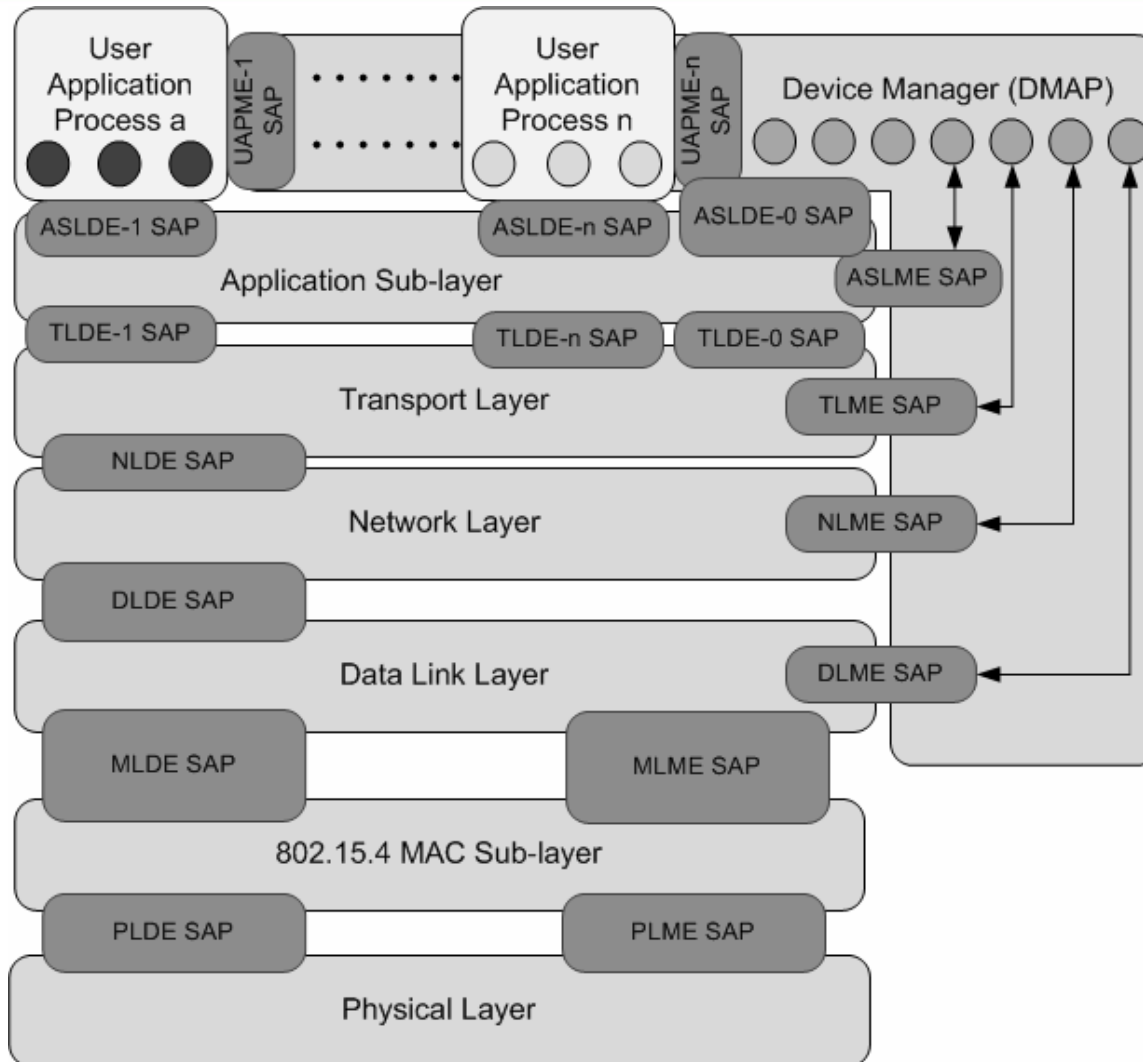

Technical Overview: System Management

Supports management of the various communications resources across the ISA100.11a network and across all layers of the architecture

- The purpose of the ISA100 management functions is to support management in the following five areas:
 - fault
 - configuration
 - accounting
 - performance
 - Security
- The primary components of the management service include a device management application process that resides on every ISA100.11a device, as well as one or more system manager applications that reside on a small subset of devices.

Technical Overview: Phy & DLL Layers

Physical layer: Radio layer

- Defined as compliant to IEEE 802.15.4-2006 2.4 GHz DSS

Data Link Layer: defines the format of data on the network

- Consists of:
 - IEEE 802.15.4-2006 MAC sub-layer
 - Upper DLL sub-layer
 - Shim layer between MAC and Upper DLL
- Upper DLL provides:
 - TDMA
 - Channel Hopping
 - Mesh routing

Technical Overview: Network Layer

Provides inter-networking routing

- The functions offered by the network layer are divided into:
 - addressing
 - routing
 - quality of service
 - management functions
- Provides inter-networking routing; i.e. provides mesh to mesh routing
- Frame format in accordance with IETF RFC 4944

Technical Overview: Transport Layer

Transparent transfer of data between end systems, or hosts, and is responsible for end-to-end error recovery

- The functions offered by the transport layer are divided into:
 - reliable/unacknowledged service
 - enhanced-secure/basic-secure service
 - flow control
 - higher level service (segmentation & reassembly, etc)
 - management topics



Technical Overview: Application sub-Layer

Provides capabilities and services to enable an open interoperable ISA100.11a application environment.

- provide support for wireless field devices and to enable a gateway to integrate an ISA100.11a wireless network and its devices with a host control system
- object-oriented modeling concepts support both ISA100.11a native and non-ISA100.11a native (legacy) protocol tunneling applications.
 - An object model is a protocol-, platform-, and language-neutral means of describing and distinguishing components (system elements) that have a unique identity

Technical Overview: Gateway

Provides portal between ISA100.11a and another system

- ISA100.11a provides support for protocol translation. The support includes a tunneling object that fits within the application layer structure and provides generic services for protocol translation.
- ISA100.11a does not provide the actual protocol translators, only the supporting mechanism.

Technical Overview: Security

Provides authentication, encryption, authorization services

- The communications security functionality for ISA100.11a release 1 is primarily transmission security with authorization based primarily on device identity and configured plant communications relationships
- Transmission security is provided for the MAC sublayer and for the transport layer
 - MAC security defends against attackers who are outside the system and do not share system secrets
 - Transport security defends against attackers who are already inside the system and have co-opted (i.e., Trojaned) some devices
- Types of keys supported include both symmetrical keys and non-symmetrical (i.e. public) keys

Conclusion

The ISA100 committee continues to be committed to rapid development to satisfy the expressed needs of the user community

- “Family of Standards” approach allows a succession of releases focused on market segments
- Consensus among a balanced membership allows the committee to rise above special interests and do what is right for the industry
- Ultimate goal is a quality standard that will stand the test of time by adapting to changes within the industrial environment